



Solutions for
Comfort & Safety



Stands for

Resisting forces flexibly

INDIA'S # 1 IN

VIBRATION & SHOCK CONTROL

Vibration Hertz Really Hurts

SEISMIC RESTRAINT SYSTEMS

AIR SUSPENSION

Ride on Air

RESISTOFLEX
W
SINCE 1947

VIBRATION & SEISMIC ISOLATION OF BUILDING & EQUIPMENTS



ROOF TOP EQUIPMENTS

Spring Isolators and Flexible Connectors prevent transmission of vibration & noise to floors under it.

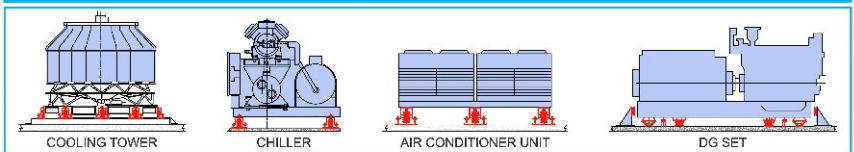

FLOATING FLOOR

For Suite, Conference & Computer Rooms, Vibration & Noise coming from the mechanical equipments must be isolated with Floating Floors & Acoustic Hangers or a Room within Room construction.

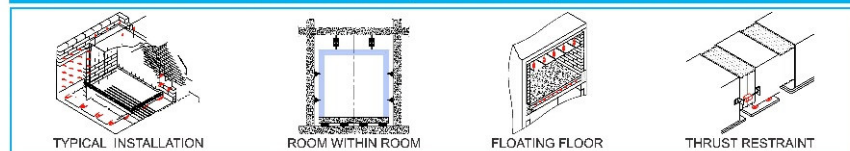

SERVICE FLOOR

AHU, Blowers, Pumps require Inertia Pouring Frames with integral Vibration Isolators. All duct work and pipe work connections must have flexible connections.

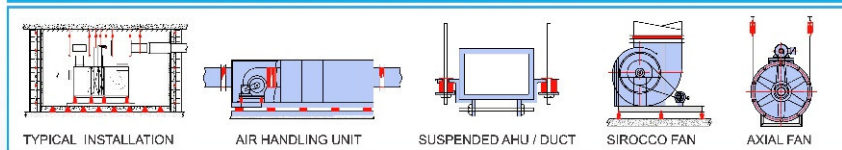

BASE ISOLATION

For disturbances from Rail Movement, Heavy Vehicles and Earth Quake.



SEISMIC BEARING

PIPELINE

Should be isolated from the building structure with Spring / Rubber Hangers or mountings and Flexible Connectors.

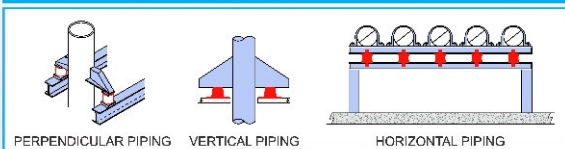

PLANT ROOM

Equipments should be installed on Aseismic Inertia Pouring Frame with integral Vibration Isolators and Seismic Snubbers.

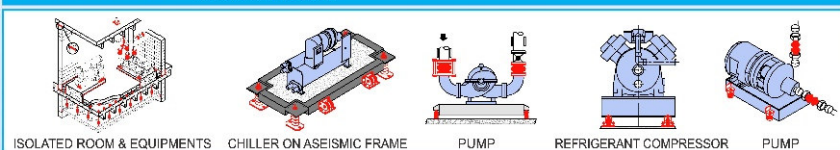

ROOFTOP ISOLATION SYSTEM FOR BUILDINGS & MEDICAL CENTRES

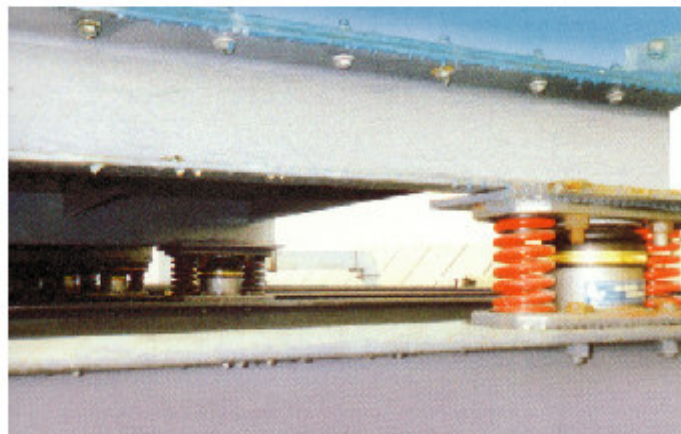

FORGING HAMMERS ON PADS

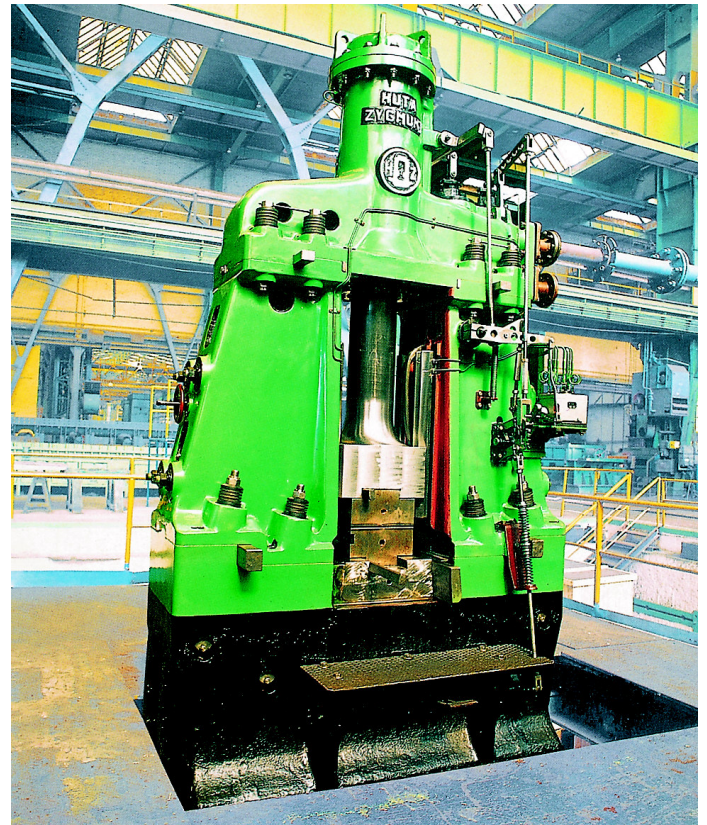

Protects buildings & prevents disturbances to adjoining equipments

HUNDREDS OF HAMMERS INSTALLED

RESISTOFLEX
SINCE 1947

JET ENGINE TEST BED ON PADS

3 INSTALLATIONS

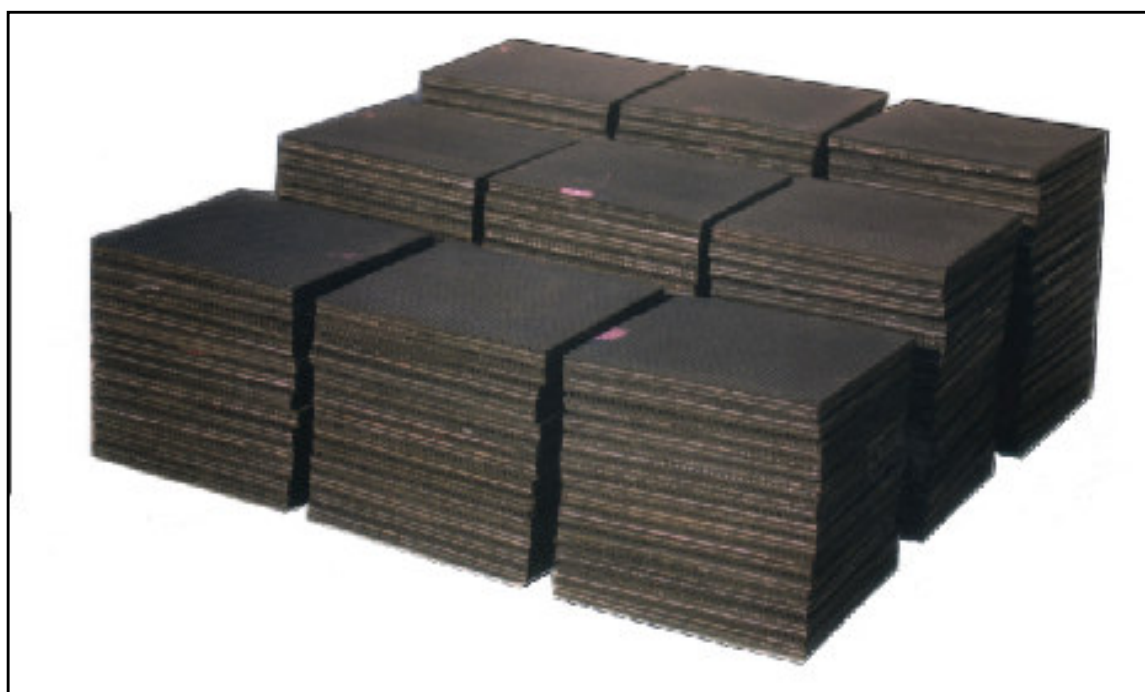
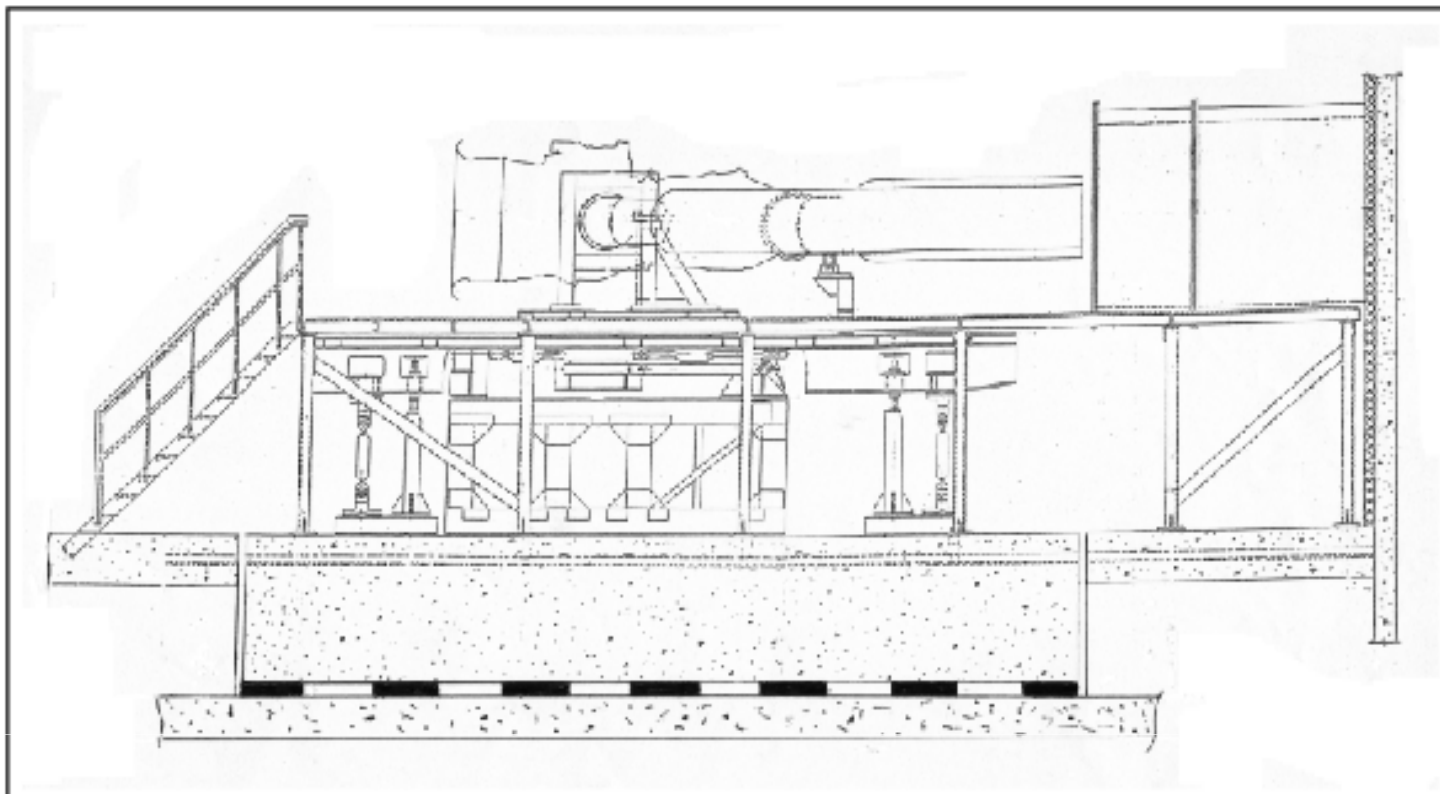

RESISTOFLEX

SINCE 1947

SHOCK & VIBRATION MOUNTINGS FOR NAVAL SHIPS



Quality, Reliability, Precision and Innovation are our fundamentals for the vital role, our products have to perform under harsh environmental conditions.

Our Collaborators



CHRISTIE & GREY
ENGLAND



socitec
FRANCE

Engineered to Perform....



MANGALYAAN - MARS ORBITER MISSION



400 Nos Vibration Isolators insulate Avionic Modules from harsh vibration, noise and nano shocks during lift off and stage separations of PSLV to the final launch of Satellite in space.

AIR BEARINGS FOR NEXT GENERATION SATELLITE LAUNCH

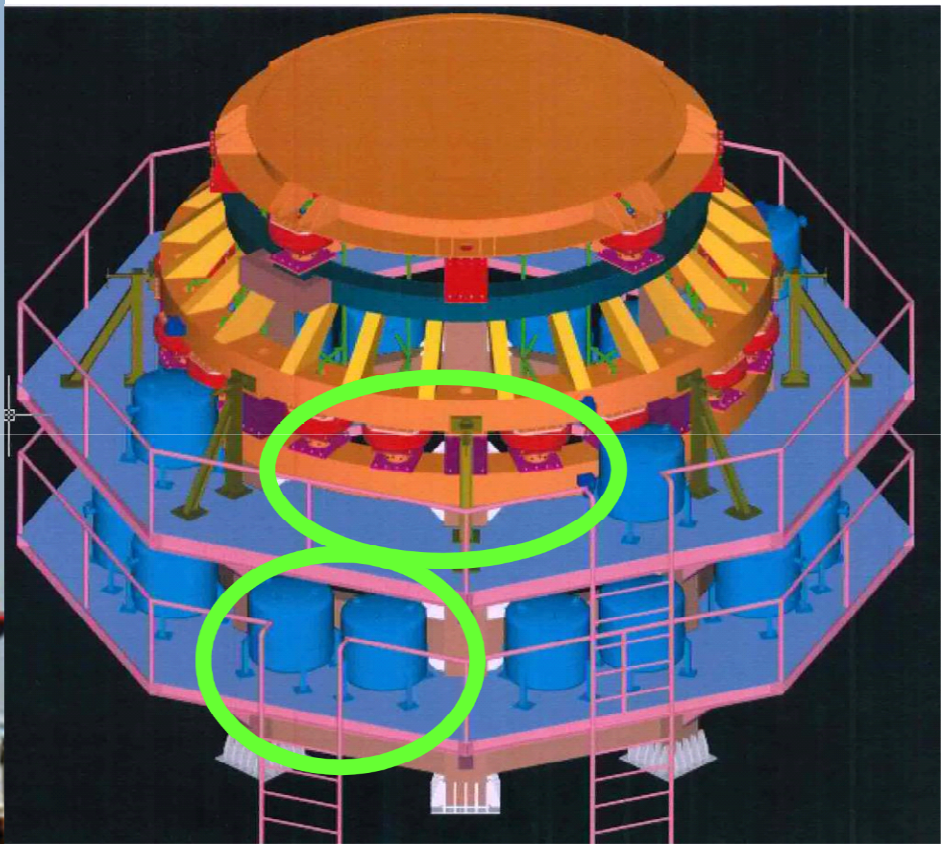

Word of Recognition

S / Shri. Ratish, Hareesh & Saxena,

Thank You very much for your wishes. The air bearings supplied were used for Characterising the next generation launch vehicle called GSLV Mk III, intended to lift 4 Ton class satellites.

I am happy to inform that all Pneumatic suspension systems developed at M/S Resistoflex worked extremely well during the ground tests, which we conducted between 2010 to 2013 and it is one of the best systems ever developed. I sincerely thank one and all of you for giving me excellent freedom in tailoring the system to our requirement and the whole hearted support provided to me.

Thanks once again and looking forward to further co-operation in future.

With regards,

Dy. Project Director (VE &S)

GSLV Mk III Project, VSSC / ISRO.

Privileged to be a part of it in resonance with the NEXT

RESISTOFLEX
SINCE 1947

INDUSTRIAL SHED ON PTFE SLIDE BEARINGS

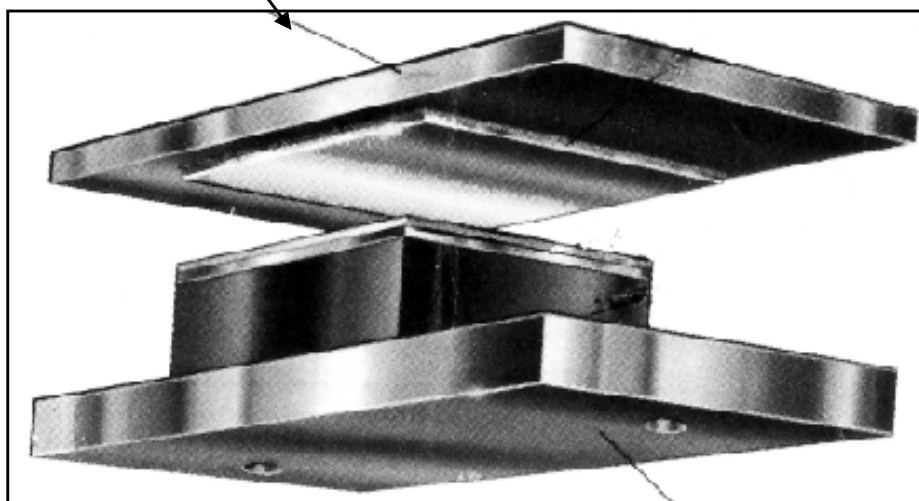

ATRIUM ON PTFE SLIDE BEARINGS

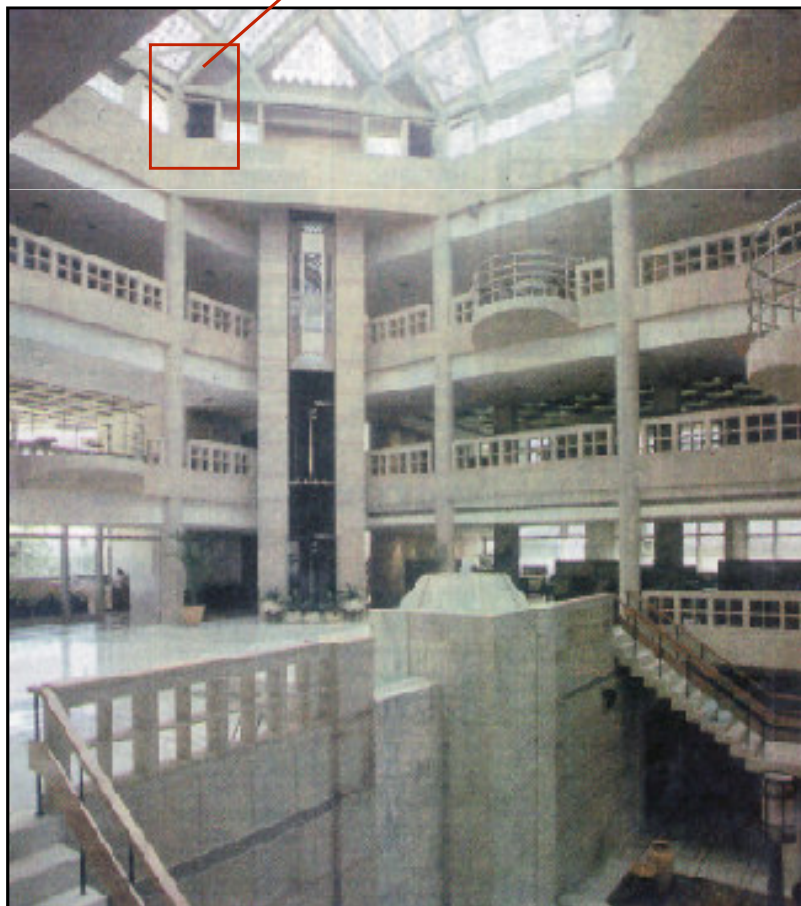

SEISMIC ISOLATION

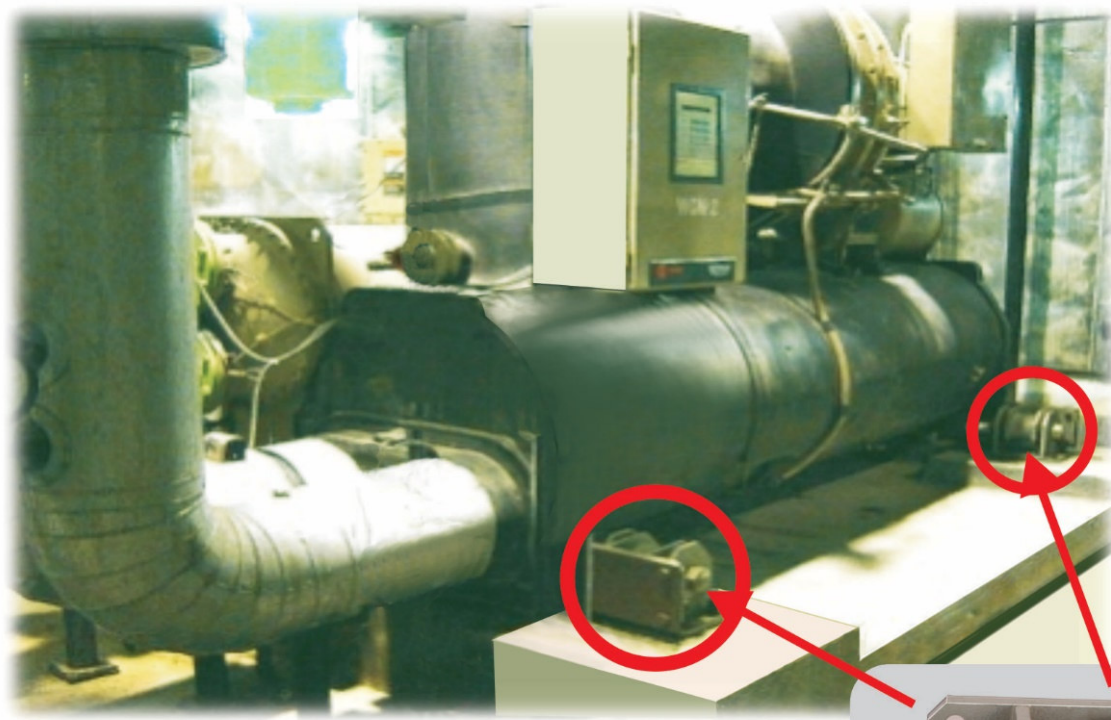
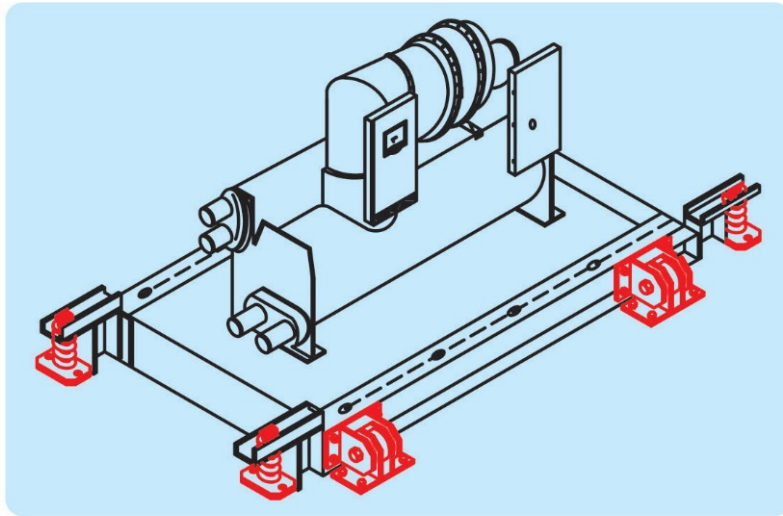

TRANE CENTRIFUGAL CHILLERS
4 Nos. x 8130 Kgs

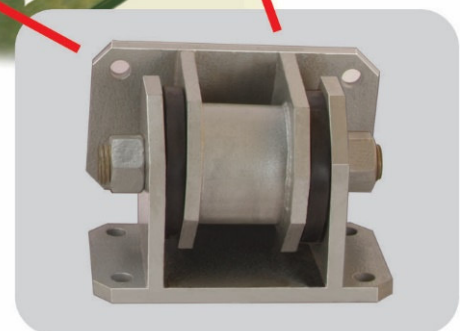

SEISMIC SNUBBER

PROJECT : KALANIDHI, KALAKOSHA
INDIRA GANDHI NATIONAL CENTRE
FOR THE ARTS, NEW DELHI

CONSULTING ARCHITECT : RALPH LERNER ARCHITECT PC

ENGINEERING CONSULTANTS : TATA PROJECTS LTD.

HVAC CONSULTANTS : SPECTRAL SERVICE CONSULTANTS (P) LTD.

CUSTOMER : ETA ENGINEERING PVT. LTD.

YEAR : 1998

SEISMIC RESTRAINTS FOR EQUIPMENTS

END SUCTION PUMP

on Spring Isolators, IPF, Seismic Snubbers & REJ

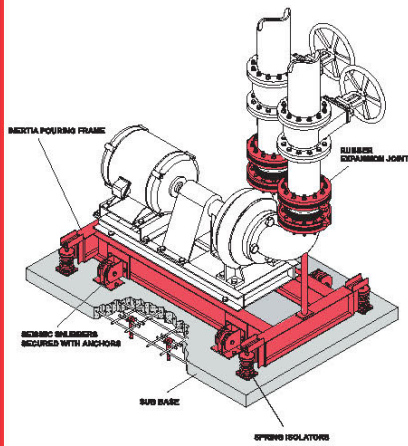

DOUBLE SUCTION PUMP

on Spring Isolators, IPF, Seismic Snubbers & REJ

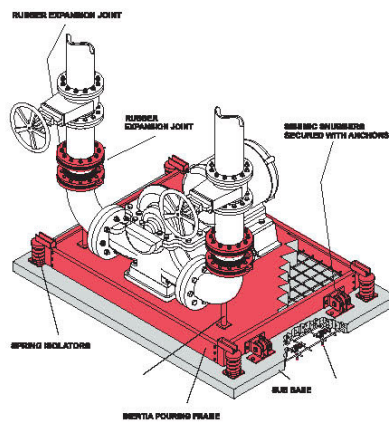

CENTRIFUGAL CHILLER

on Spring Isolators, IPF, Seismic Snubbers & REJ

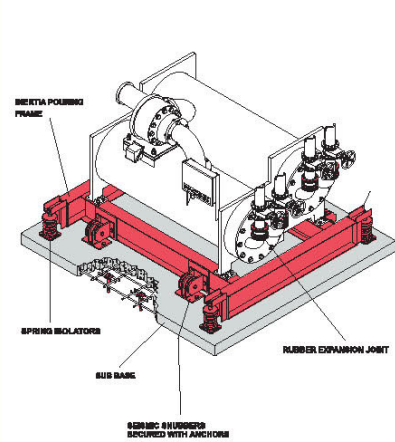

CENTRIFUGAL BLOWER

on Spring Isolators, IPF & Seismic Snubbers

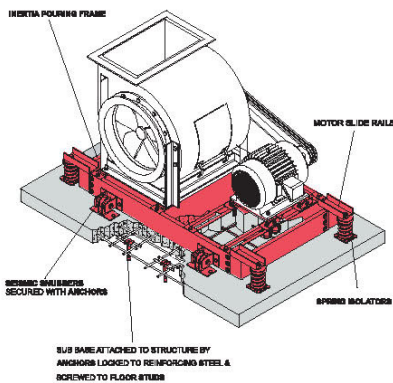

DEVICES

for Seismic Protection



COOLING TOWER

on Restrained Spring Isolators and REJ

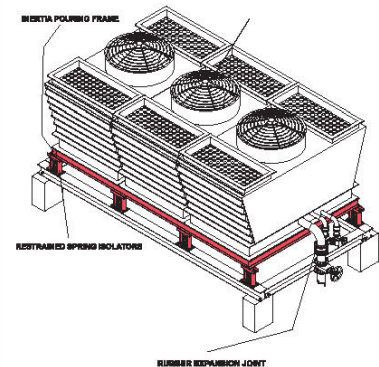

COMPRESSOR

on Restrained Spring Isolators and Anchors

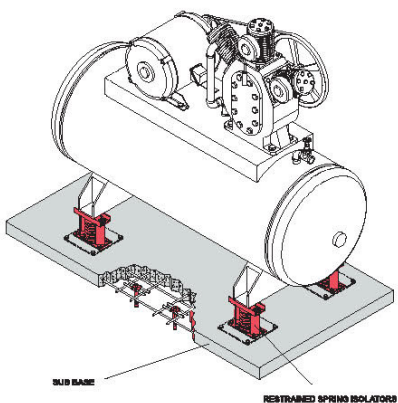

STEAM GENERATOR

on Restrained Spring Isolators and Anchors

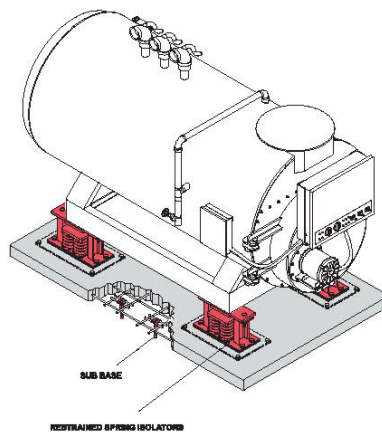

TRANSFORMER

on Air Spring Isolators, IPF & Seismic Snubbers

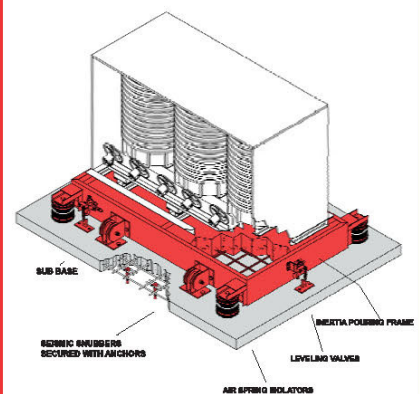

Some prestigious projects:

- Airport in Middle East
- Omkar Worli
- DAICEC
- American Embassy
- Kiran Agro

**For Pumps, Chillers, DG Sets,
Transformers, Panels, Boilers, Storage
Tanks, Compressors, AHU, Heat
Exchangers, Condensers, Cooling Towers,
Fans, Blowers.....**

BASE ISOLATION SYSTEM

- 8 BUILDINGS FOR A DEFENCE PROJECT

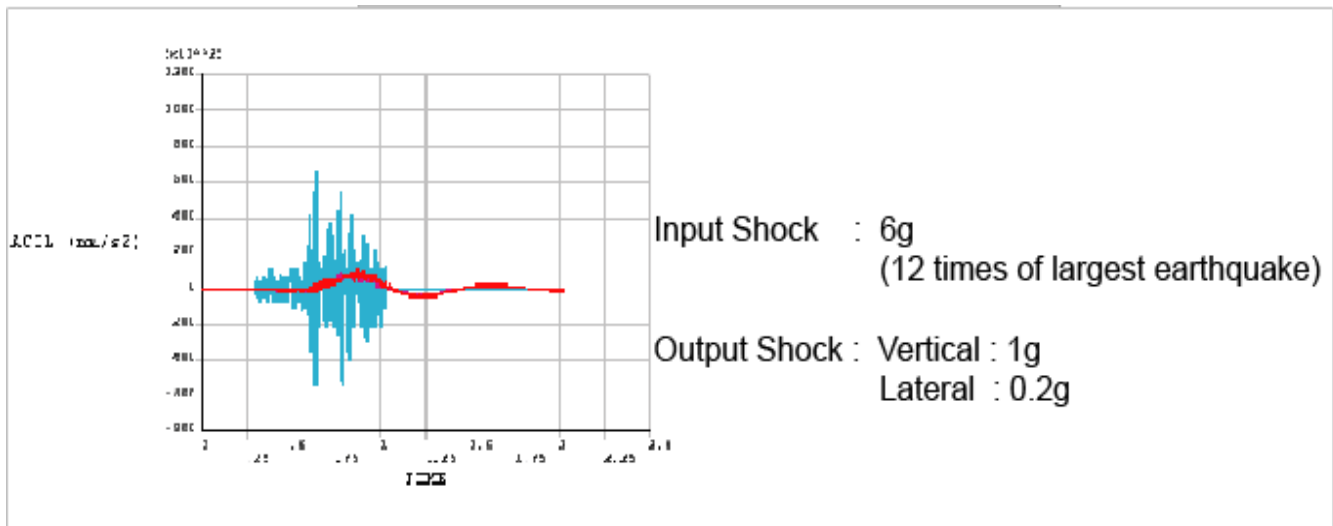

Success Motivated us
to bring
BASE ISOLATION TECHNOLOGY
to
CIVIL BUILDING DOMAIN
at
Affordable Prices

RESISTOFLEX

SINCE 1947

Seismic Isolation Systems

in collaboration with



for economy, safety and continuous performance of buildings
.....Taming Tremors

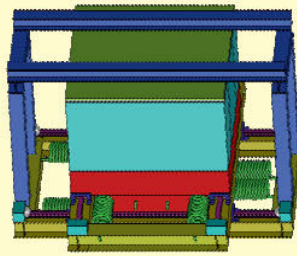
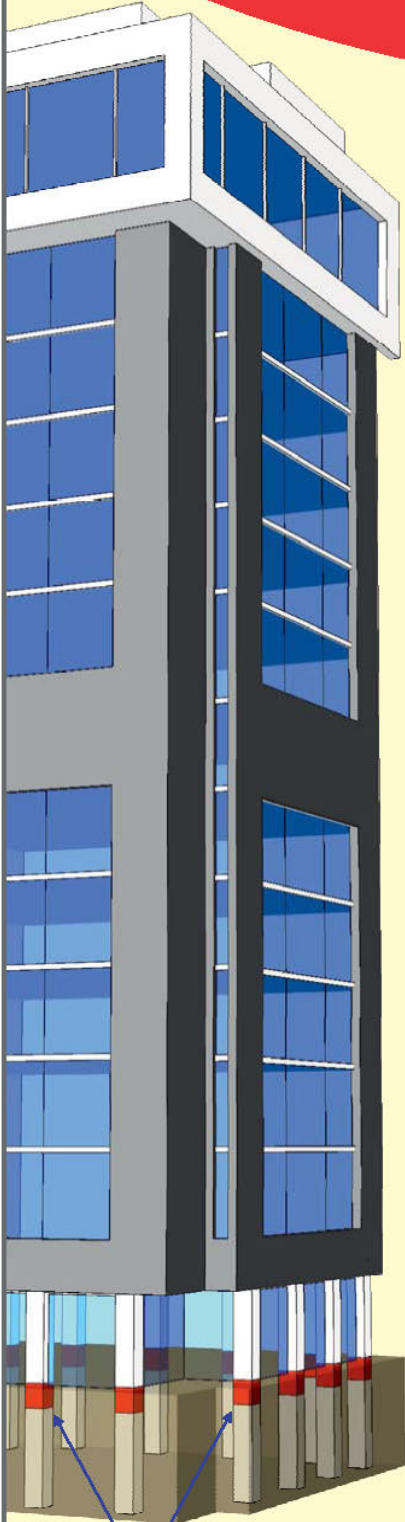

Tuned Mass Damper



Viscous Damper



Hysteretic Dampers



Lead Rubber Bearing



Sliding Pendulum Isolator

SEISMIC BEARING

Decouples the buildings from the ground and absorbs the earthquake energy.

PROJECTS IN INDIA

**IT SEZ, 36 Storey Residential Building
Corporate Office, Hospital, Tall Statue**

IT / ITES SEZ at Gurugram, Haryana



FLOORS : 2 BASEMENT + GROUND + 6 FLOORS
AREA : 100 M X 100 M
WEIGHT : 107000 TONS
ISOLATORS : 254
LOCATION : LOWER BASEMENT

PERFORMANCE CHARACTERISTICS



Equivalent radius	: 7000 mm
Dynamic friction	: 0.02
Natural period of the building	: 4 s
Equivalent viscous damping	: 27.9%
Acceleration	: 0.0453 g
Building Displacement	
@ center of mass	: ± 180 mm
@ edge	: ± 180 mm

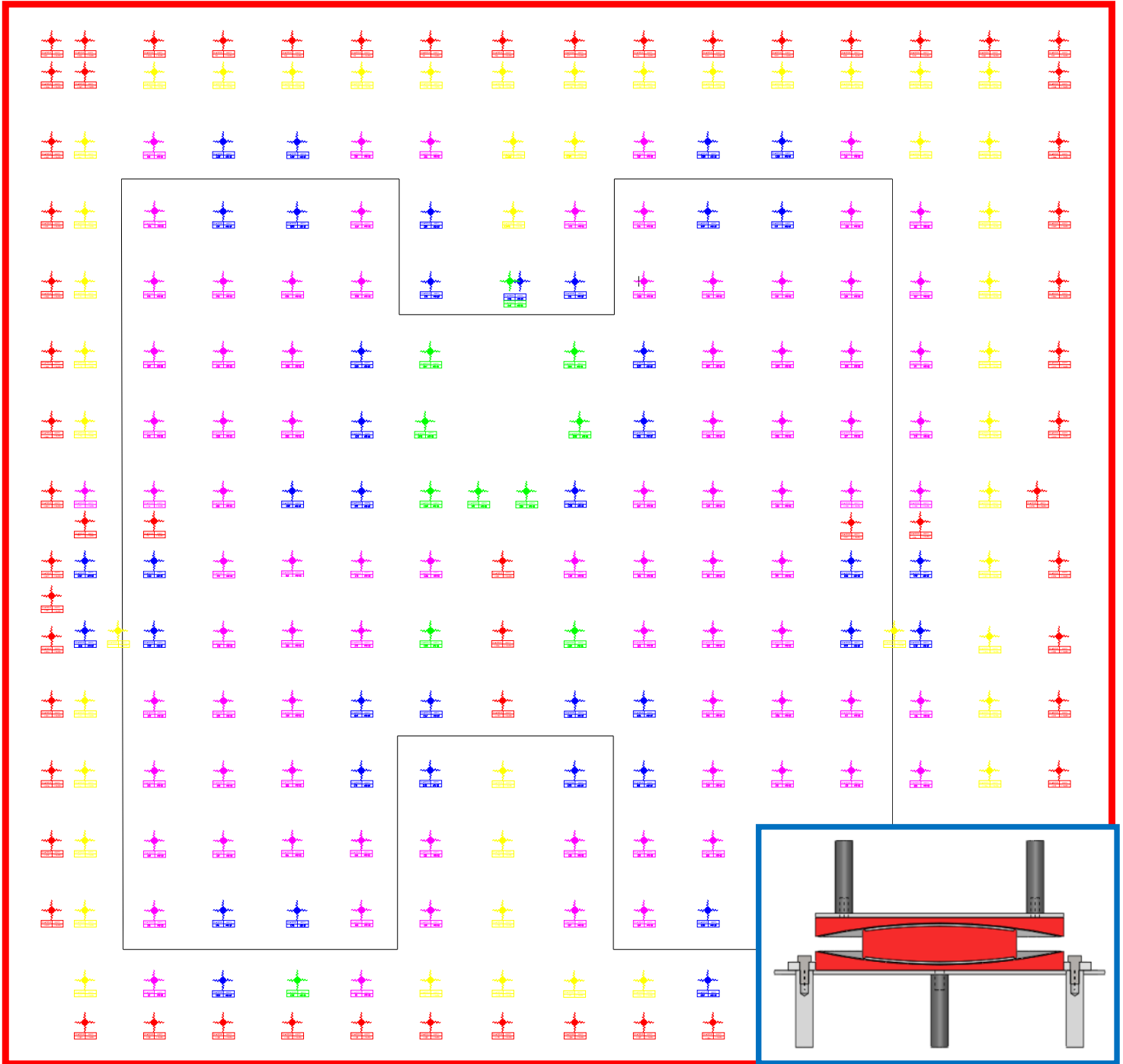

Location MAP of Friction Pendulum Isolators with double sliding surface (5 types) for IT/ITES BUILDING

IT/ITES SEZ at Gurugram, Haryana



Isolators now under Installation



COLLABORATIVE PROJECT
with
INDIAN INSTITUTE OF TECHNOLOGY, DELHI
for

**SEISMIC BASE ISOLATED
SHOWCASE BUILDING**



Sliding Pendulum Isolator

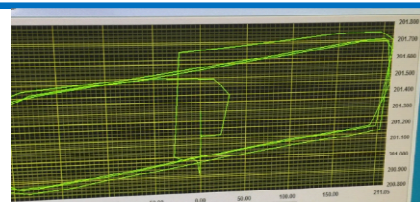
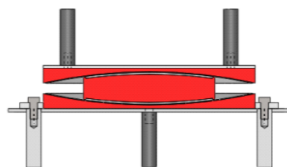

Mentor
Prof Chandan Ghosh, NIDM

INDIAN INSTITUTE OF TECHNOLOGY (IIT) DELHI – PERSPECTIVE

- IITD will support this Lab-to-Land landmark project.
- Exhibit structure will serve for increasing awareness and transferring the state-of-the-art technology to our society in India.
- Real-time monitoring to assess its seismic performance and demonstrate effectiveness of this matured technology.
- Selection of Sliding Pendulum Isolators
..... a thoughtful decision.
- Confidence building in stakeholders.

Dr. Vasant Matsagar
(Associate Professor)
Department of Civil Engineering,
Indian Institute of Technology (IIT) Delhi,

MENTOR'S PERSPECTIVE

- Technology can benefit several existing seismically deficient buildings.
- Live example for the building industry, common people and government policy makers.
- Project site sub-soil profile is consistently good and additional micro piling will ensure building foundation remains unaffected by differential settlement.
- Raft foundation with simple densification of sandy silty sub-soil will compact additional 1.5m depth.
- Due care to ensure that soil strata remains uniform & free from liquefaction by local distant earthquake.

Prof. Chandan Ghosh

National Institute of Disaster Management (NIDM), New Delhi

STRUCTURAL ENGINEER'S PERSPECTIVE

- RCC Column-Beam frame arrangement with RCC slab & Base-Isolators at Stilt Floor roof base.
- Designed to IS:1893 (Part1) / IS:13920.
- Used nonlinear time history owing to the accuracy of equivalent stiffness analysis results.
- Designed elastically to the MCE level of loading.
- Design being reviewed and guided by IITD to ensure desired performance. The staircase structurally separated & Lift Well detailed with hanging walls/pit up to the basement level, supported above stilt floor.

Aman Deep Garg

Creative Design Consultants & Engineers Pvt. Ltd.

ARCHITECT'S PERSPECTIVE

- Designed to remain functional during severe earthquakes predicted for Zone 4.
- Building will showcase a technological advancement in Architectural field

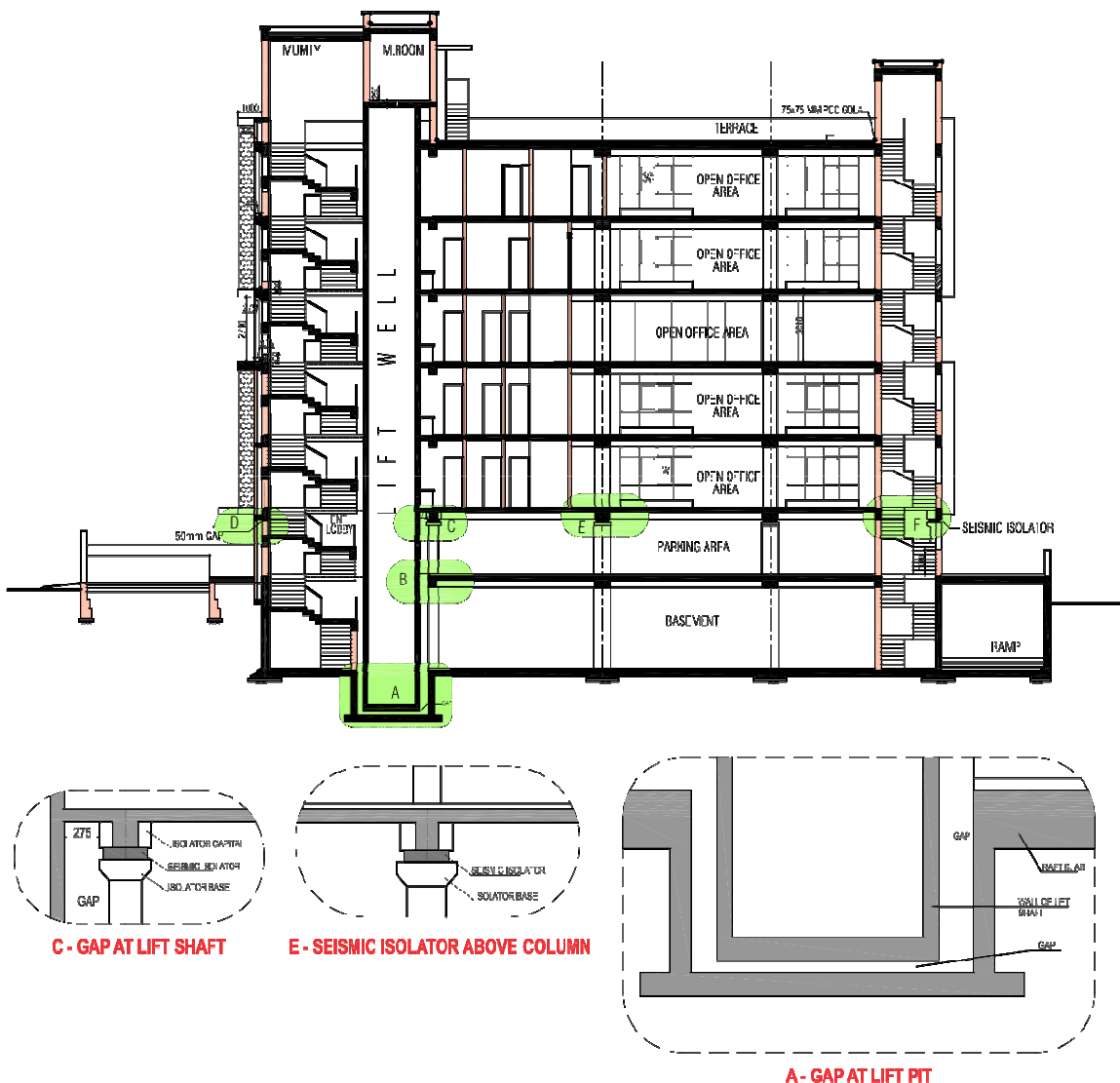

Anil B Jain
Director
Grup.Ism Pvt. Ltd. (Architects)

A COMPLETE SEISMIC ISOLATION SYSTEM

- a) Building Isolation System using Sliding Pendulum Isolators**
- b) Lift Isolation System**
- c) Stair Case Isolation System**
- d) Piping Isolation System using Gimbal & Universal Metal/Rubber Expansion Joints**
- e) Flexible Conduit System**

TECHNICAL DATA

NORMAL BEHAVIOUR:

Friction coefficient : 2%
-)damping: 27.9%
-)period: 4sec
-)stiffness: $V*0.000255$
kN/mm
-)max H load: 4.5%
-)max displacement: 180mm

UPPER BOUND BEHAVIOUR:

Friction coefficient: $2%*1.2$
 $\rightarrow 2.4%$
-)damping: $>30%$ (31.9%)
-)period: 3.7sec
-)stiffness: $V*0.000286$
kN/mm
-)max H load: 4.8%
-)max displacement: 170mm

LOWER BOUND BEHAVIOUR:

Friction coefficient: $2%*0.8$
 $\rightarrow 1.6%$
-)damping: 22%
-)period: 4.3sec
-)stiffness: $V*0.00022$
kN/mm
-)max H load: 4.6%
-)max displacement: 212mm

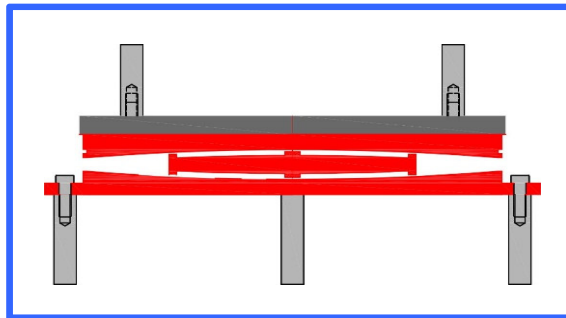
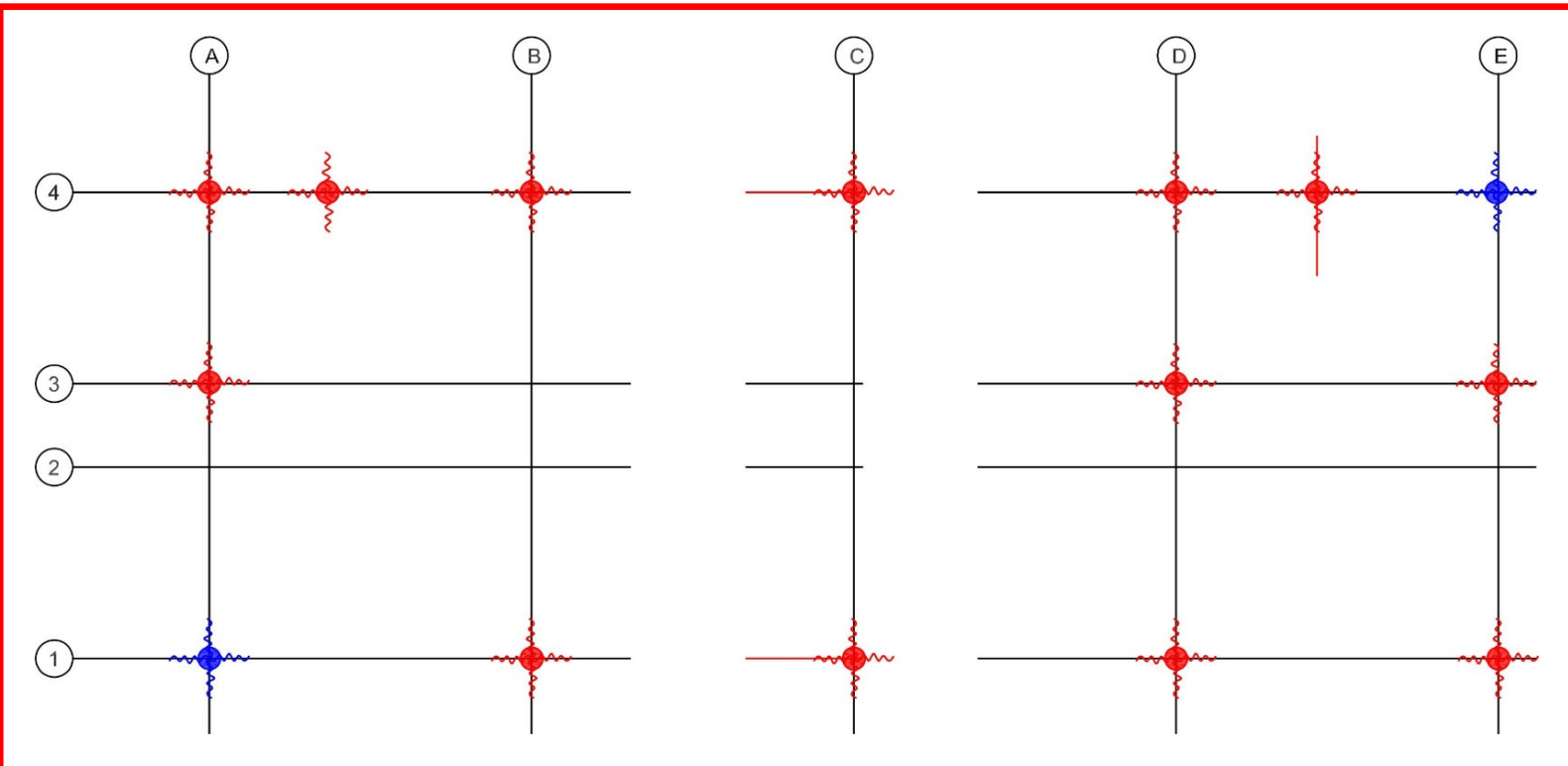

Location MAP of Friction Pendulum Isolators with double sliding surface (2 types)

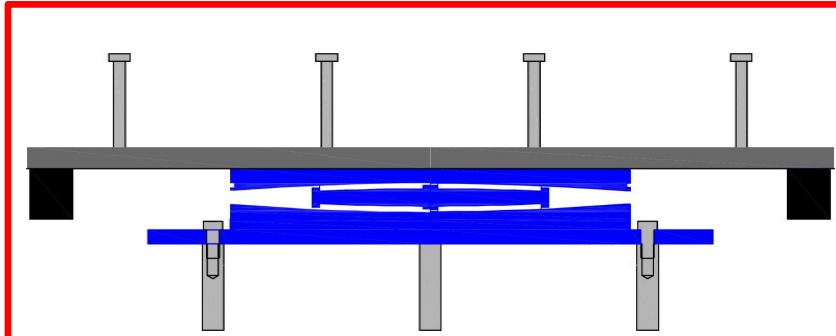
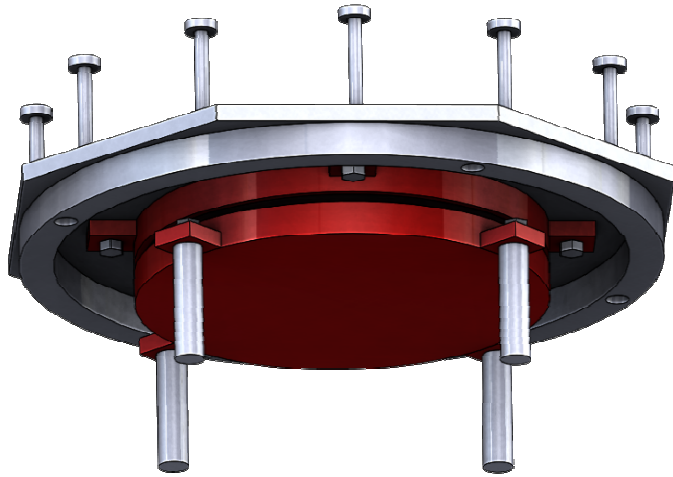

2 Special Pendulum Isolators with fuse

These 2 units will be installed with a special fuse system in order to ensure that all the pendulums move in the same direction and avoid the pendulums exceeding their movement capacity.

To optimize this technology, the 2 fuse pendulum will be placed in the diagonal direction of the structure.

SHOWCASE BUILDING



**Isolators are Expected
to be installed
around
End of May 2017**

SEISMIC SMART

A special feature added to this building will be to integrate sensors to instantly convey to all stakeholders and occupants through Mobiles/Internet about the incoming Seismic intensity and that actually transmitted to the building's upper structure to emphasize the safety aspects.

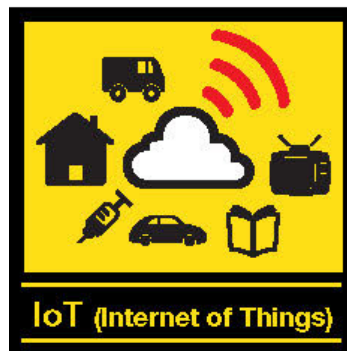

..... *Truly Seismic Smart*

PENDULUM TEST



The devices for the IT/ITES and Showcase buildings have been successfully tested in accordance with the European standard EN15129 and, the given specifications.

PROTOTYPE TEST

Load Bearings Capacity
Friction Test
Sliding Isolation Test

Long Term Friction Test

ROUTINE TEST

Load Bearing Capacity Friction Test
Benchmark Isolation Test

The results obtained are totally within the tolerances described in the EN15129 and can guarantee the good performances of the provided isolation system



**We will be happy to
engage with your
projects
for**

SEISMIC ISOLATION

Remember



WHEN

HIMALAYA

SHIVERS

INDIA

QUIVERS

Base 802813AI (C00213) 10-01

RESISTOFLEX
SINCE 1947

**High time we followed the
Global Ideology
and move**

from
EARTHQUAKE RESISTANCE
to
SEISMIC ISOLATION

.....to *Protect People & Property*

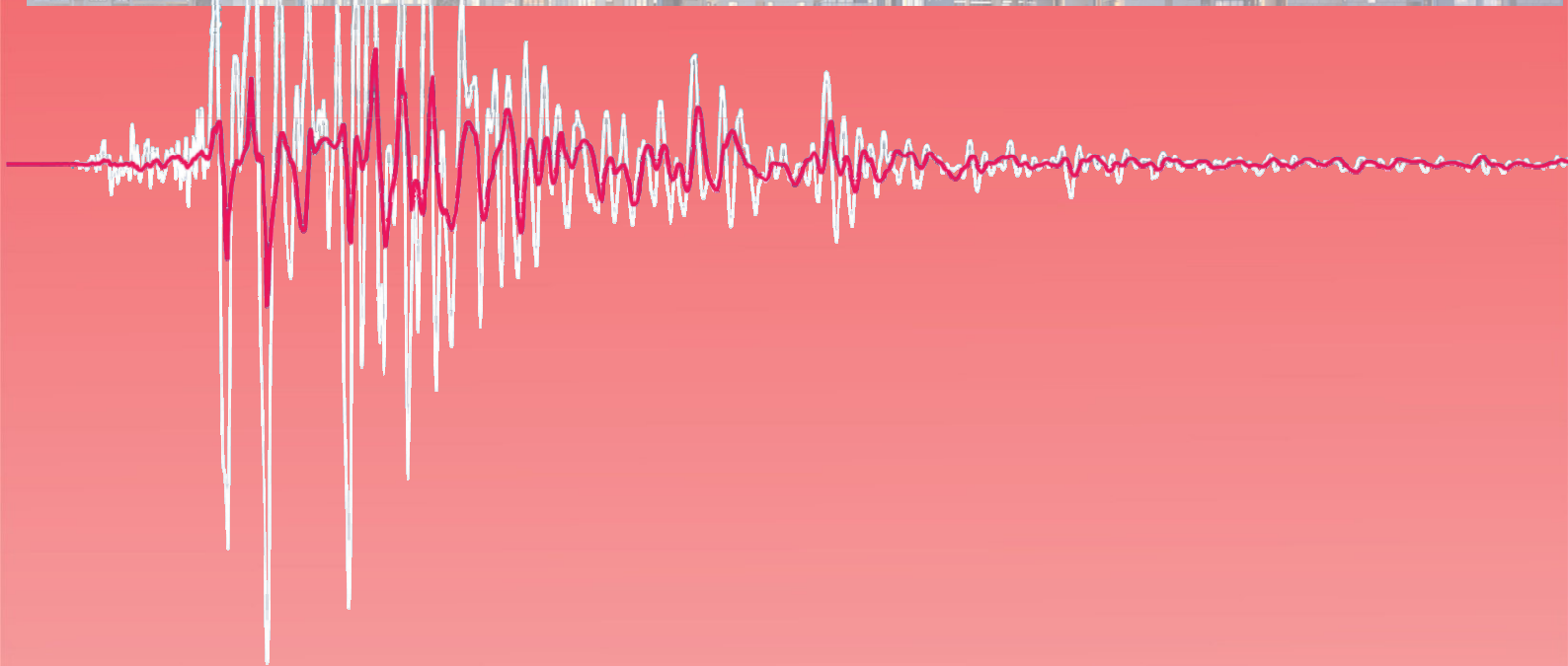

RESISTOFLEX
SINCE 1947

